

ROG

Flexible rope style AC current sensors - 131 mV Up to 4000 A



ROG
131 mV / 1 kA

Function

The **ROG Rogowski current sensors** are flexible rope style AC current sensors available in four diameters (80mm, 120mm, 200mm and 300mm).

These Rogowski sensors deliver an output signal of 131 mV / 1000 A @60Hz, and are compatible with the DIRIS MCM power meters, with no additional integrator or power supply required.

The rope style and the low voltage output signal make them non-intrusive and ideal for retrofit applications with existing electrical panels having limited space.

They are ideal for applications with high currents, busbars and multiple sets of parallel conductors where conventional rectangular or rigid split-core sensors will not fit.

Advantages

Safe installation

- The open-ended design facilitates installation without disconnecting electrical wires inside the panel.
- Built-in burden resistor provides 131 mV voltage output at the rated full scale current, eliminating the need for shorting blocks.

Flexible installation

The rope-style concept provide significant installation flexibility for cable bundles, busbars and irregularly shaped conductors, where conventional rectangular or rigid CTs will not fit.

Safe locking mechanism

The locking mechanism prevents the loop from opening accidentally, guaranteeing continuous functioning and accuracy even under harsh conditions.

Accurate

The ROG split-core sensors deliver linear 0.5% accuracy across a wide current range, essential for accurate power and energy measurements.

Long lead wires

The ROG series come with standard 22-ft / 7m 3-wire output lead, ideal when the meter is installed remote from the electrical panel. This reduces the need for contractors to extend and splice wire leads which typically increases the risk of wiring errors.

The solution for

- > Buildings
- > Industry
- > Datacenter
- > Renewables

Strong points

- > Safe installation
- > Flexible installation
- > Accurate
- > Long lead wires
- > Safe locking mechanism

Conformity to standards

- > UL 2808, CAN/CSA C22.2 No. 61010-1-12, File E257746
- > IEC 61869-10



Associated products

- > DIRIS MCM



Dimensions (in / mm)

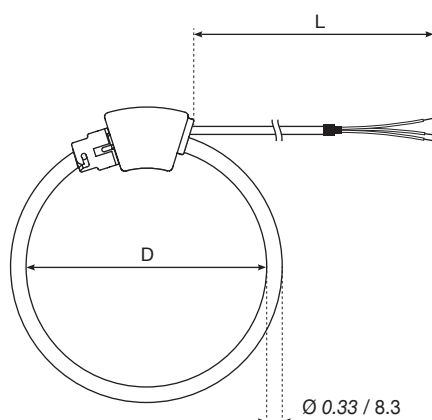

Model	D (in/mm)	Loop length (in/mm)	L (ft/m)
ROG-80	3.15 / 80	9.88 / 251	22 / 7
ROG-120	4.72 / 120	14.84 / 377	22 / 7
ROG-200	7.87 / 200	24.72 / 628	22 / 7
ROG-300	11.81 / 300	37.09 / 942	22 / 7

Technical Characteristics

Ideal for busbars or higher currents	Rogowski 131 mV current sensors			
	ROG-80	ROG-120	ROG-200	ROG-300
Maximum input current	4000 A			
Output signal	131 mV / kA @ 60Hz 109.2 mV / kA @ 50 Hz			
Output lead wires	2 x 24 AWG conductors (White/Black), twisted pair, with crimped pins, 600 V, shielded			
Lead length (ft / m)	22 / 7			
Accuracy	0.5% (*)			
Phase orientation	Arrow points towards Load			
Voltage rating	600 VAC			
Coil Jacket Material	Thermoplastic vulcanizate (TPV), UL 94 V-0 flame rating			
UL compliance	ANSI/CAN/UL 2808, CSA C22.2 NO. 61010-1-12			
Operating temperature	-31 ... +167°F / -35 ... +75°C up to 2000 A -31 ... +140°F / -35 ... +60°C from 2000 A to 4000 A			
Operating altitude	< 2000 m			
Operating humidity	95% RH without condensation			

(*) Following best practices for positional sensitivity and external signal integration.

References

Model	Window (in/mm)	Reference
ROG-80	Ø 3.15 / 80	194S 1080
ROG-120	Ø 4.72 / 120	194S 1120
ROG-200	Ø 7.87 / 200	194S 1200
ROG-300	Ø 11.81 / 300	194S 1300