

Core balance transformers - type A

Dedicated to RESYS



Split-core balance transformer Δ IP-R

lore_061.psd



Core balance transformer WR

lore_015.eps



Core balance transformer Δ IP-C

lore_046.psd

The solution for

- > Industry
- > Infrastructure
- > Non critical buildings
- > OEM
- > Renewable energy



Strong points

- > A complete product range
- > A wide range of fixing systems (Δ IC & Δ IP-R)
- > A patented cable locator (Δ IC & Δ IP-R)
- > A rapid installation and safe implementation (Δ IP-R)

Conformity to standards

- > IEC 61869-1



Function

The installation of protection or monitoring systems such as earth leakage protection relays involves the use of **core balance transformers**.

Active conductors pass through the aperture of the core balance transformer, providing the differential summation of vector currents which enables the detection of leakage currents. The core balance transformers (toroids) proposed by SOCOMEC meet requirements in terms of measurement sensitivity and are suitable for earth leakage protection relays RESYS M40/P40.

Closed (series Δ IC, WR and TFR) or split-core (series Δ IP-R) types, suit all wiring configurations.

Advantages

A complete product range

All dimensions and types are available for compatibility with any bar and cable configurations or diameters.

A wide range of fixing systems (Δ IC & Δ IP-R)

Δ IC & Δ IP-R core balance transformers can be mounted on DIN-rail, on back-plate or directly on the cable. These products can be adapted into confined spaces with high integration constraints and provide easy and rapid cabling.

A patented cable locator (Δ IC & Δ IP-R)

The SOCOMEC cable locator is a patented innovation. The cable is perfectly centralised in the core balance transformer to ensure accurate measurement and enhanced immunity to network interferences. It also enables direct mounting of the core balance transformer onto the cable.

A rapid installation and safe implementation (Δ IP-R)

Thanks to an innovative “one click” opening/closing system, without the need of additional accessories, split-core Δ IP-R toroids have been designed to ensure a fully safe installation.

Implementation

All of the active conductors must be passed through the detection toroid's aperture. The protective conductor must pass on the outside of the toroid or pass once for each direction.

Installation limiting distortions during heavy load switching.

Installation of the detection toroids



isom_067_a_1_x_cat.eps

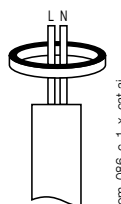
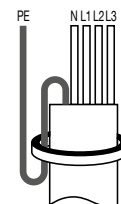
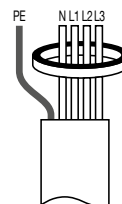

isom_086_c_1_x_cat.ai

Characteristics

Electrical characteristics	Δ IC	Δ IP-R
Insulation coordination	according to IEC 60664-1	according to IEC 60664-1
Max. operating voltage	720 VAC	720 VAC
Rated impulse voltage	8 kV	8 kV
Assigned withstand voltage	3 kV	3 kV
Degree of pollution	3	3
Winding ratio	600 / 1	600 / 1
Rated primary current	10 A	10 A
Nominal power	20 mVA	50 mVA
Max. accuracy class	3	3
Operating temperature	-40 ... +80 °C	-40 ... +80 °C
Flammability class	UL94V-0	UL94V-0

Electrical characteristics WR & TFR series	
Insulation coordination	according to IEC 60664-1
Insulation voltage	690 VAC
Rated impulse voltage	8 kV
Dielectric quality	6 kV
Degree of pollution	3
Winding ratio	600 / 1
Rated primary current	10 A
Nominal power	50 mVA
Max. accuracy class	5
Operating temperature	-10 ... +55 °C
Flammability class	UL94V-0

Dimensions

Closed toroids - Δ IC series

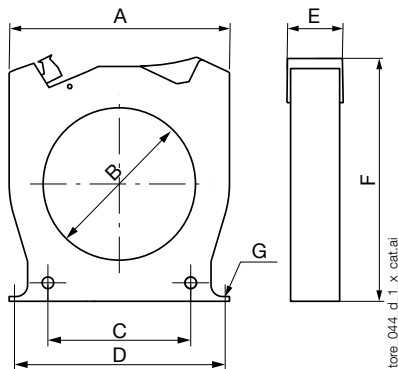

Type	A	B	C	D	E	F	G	Weight (kg)
Δ IC \varnothing 15	53	17.3	27.8	50	26	81	M4	0.10
Δ IC \varnothing 30	92	30	50	85	26	103.5	M4	0.13
Δ IC \varnothing 50	102.5	50	50	90	26	125	M5	0.18
Δ IC \varnothing 80	116	80	75	105	26	142.5	M5	0.22
Δ IC \varnothing 120	163	120	100	150	26	182.5	M6	0.38
Δ IC \varnothing 200	253	200	150	175 x 41.2	51	274	M6	0.88
Δ IC \varnothing 300	370	300	200	250 x 41.5	50	390	M6	1.72

A. Width
 B. Diameter
 C. Distance between fixing centres
 D. Distance between rear fixing brackets
 E. Depth
 F. Height
 G. Diameter of fixing screws

Rectangular closed toroids - WR series

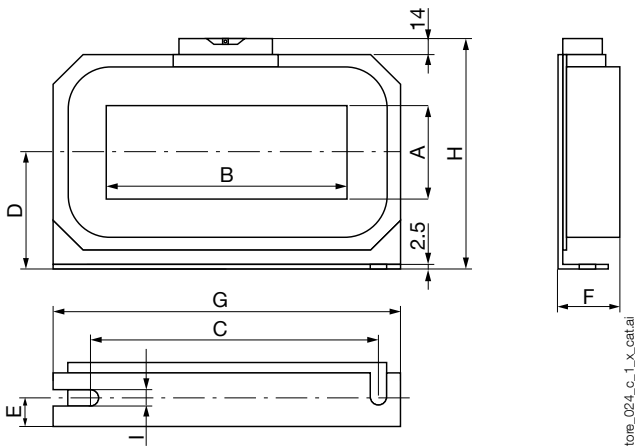

Type	A	B	C	D	E	F	G	H	I	Weight (kg)
WR 70 x 175	70	175	225	85	22	46	261	176	7.5	2.9
WR 115 x 305	115	305	360	116	25	55	402	240	8	6.3
WR 150 x 350	150	350	415	140	28	55	460	285	8	8.2

A. Height of gateway window
 B. Width of gateway window
 C. Entraxe de fixation
 D. Half-height from the base
 E. Position of oblong slot
 F. Depth
 G. Largeur
 H. Height
 I. Width of oblong slot

Rectangular closed toroids - TFR series

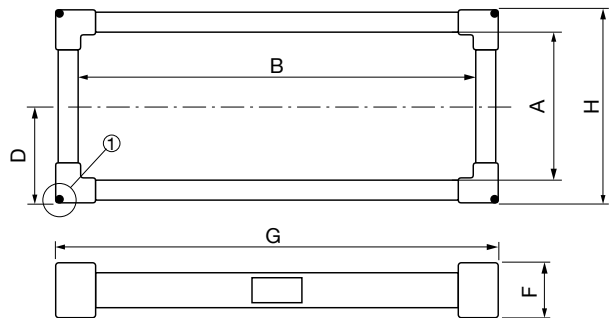

① Detail for fastening the core balance transformer

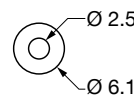

Type	A	B	D	F	G	H	Weight (kg)
TFR 200 x 500	200	500	140	62	585	285	7.2

A. Height of gateway window
 B. Width of gateway window
 D. Half-height from the base
 F. Depth
 G. Largeur
 H. Height

Core balance transformers - type A

Dedicated to RESYS

Dimensions (continued)

Split-core toroids - Δ IP-R

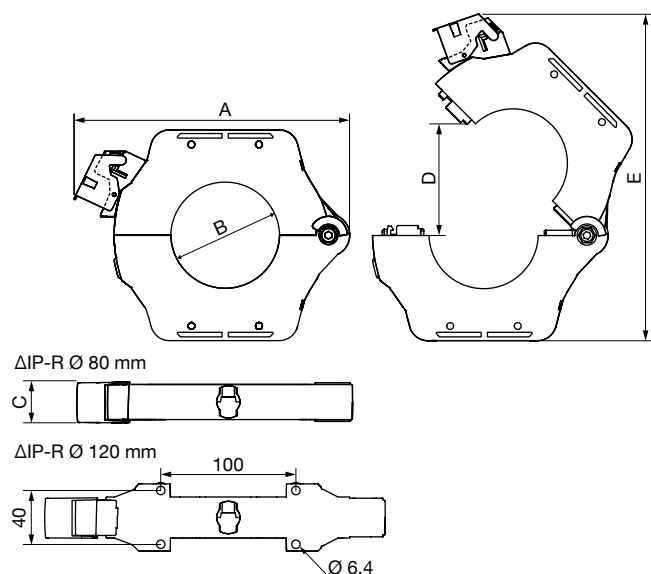

Type	A	B	C	D	E	Weight (kg)
Δ IP-R \varnothing 80	204	79	30	108	260	0,85
Δ IP-R \varnothing 120	252	119	30	149	328	1,5

A. Width
B. Diameter
C. Depth

D. Maximum opening.
E. Device height when open

References

Closed toroids type A - Δ IC series

Type	Rated operational current I_n (A)	Toroid diameter (mm)	Reference
Δ IC \varnothing 15	36	15	4950 6015 ⁽¹⁾
Δ IC \varnothing 30	65	30	4950 6030 ⁽¹⁾
Δ IC \varnothing 50	85	50	4950 6050 ⁽¹⁾
Δ IC \varnothing 80	160	80	4950 6080 ⁽¹⁾
Δ IC \varnothing 120	250	120	4950 6120 ⁽¹⁾
Δ IC \varnothing 200	400	200	4950 6200 ⁽¹⁾
Δ IC \varnothing 300	630	300	4950 6300 ⁽¹⁾

(1) Toroids for RESYS relays M40 / P40.

Rectangular closed toroids type A - WR and TFR series

Type	Toroid diameter (mm)	Reference
WR 70 x 175	70 x 175	4795 0717 ⁽¹⁾
WR 115 x 305	115 x 305	4795 1130 ⁽¹⁾
WR 150 x 350	150 x 350	4795 1535 ⁽¹⁾
TFR 200 x 500	200 x 500	4795 2050 ⁽¹⁾

(1) Toroids for RESYS relays M40 / P40.

Split-core toroids type A - WS series⁽²⁾

Type	Rated operational current I_n (A)	Toroid diameter (mm)	Reference
Δ IP-R \varnothing 80	160	80	4750 6081 ⁽¹⁾
Δ IP-R \varnothing 120	250	120	4750 6121 ⁽¹⁾

(1) Toroids for RESYS relays M40 / P40.

(2) DELTA IP-R cores are supplied with a sealable protective cover, plug-in spring terminal block and DIN rail attachment.

Accessories for Δ IC & Δ IP-R toroids

Cable locator

Enables the cables to be centred in the toroid's aperture. Use of this accessory allows the core balance transformer to be directly mounted onto the cables.

Description of accessories	Reference
Cable locator, \varnothing 30 mm	4950 0011
Cable locator, \varnothing 50 mm	4950 0012
Cable locator, \varnothing 80 mm	4950 0013
Cable locator, \varnothing 120 mm	4950 0014



Mounting bracket

Description of accessories	Reference
Mounting bracket, \varnothing 30 mm	4950 0001
Mounting bracket, \varnothing 50 mm	4950 0002
Mounting bracket, \varnothing 80 mm	4950 0003
Mounting bracket, \varnothing 120 mm	4950 0003
Mounting bracket, \varnothing 200 mm	4950 0004
Mounting bracket, \varnothing 300 mm	4950 0005



Detachable screw terminal

Description of accessories	Reference
Detachable screw terminal	4950 0041



Detachable push-in terminal

Description of accessories	Reference
Detachable push-in terminal	4950 0040



Sealable protection cover

Description of accessories	Reference
Sealable protection cover	4950 0020



DIN-rail clip

For DIN-rail mouting SOCOMEC core balance transformers.

Description of accessories	Reference
DIN-rail clip	4950 0031

